

Introducing ImageStream^x
See what you've been missing



amnis[®]

Seeing is Believing, but ImageStream[®] is Proof

If you rely on flow cytometry or microscopy, you need the power of the new ImageStream^X

A BREAKTHROUGH INTERSECTION OF TECHNOLOGIES

Amnis proudly introduces the new ImageStream^X imaging flow cytometer, a tremendous leap forward in cell analysis. Amnis has dedicated 10 years to combining the most advanced technologies in optics, sensors, and image processing to achieve what has never been possible before – a fusion of the analytical power of flow cytometry with the visual detail of imaging.

The ImageStream^X quantifies both the intensity and the location of fluorescent probes and can image at incredibly high rates of speed, allowing you to analyze rare sub-populations and highly heterogeneous samples with statistically robust and objective results. By combining the speed, sensitivity, and phenotyping abilities of flow cytometry with the detailed imagery and functional insights of microscopy, the ImageStream^X will rapidly advance your research.

WITH THE IMAGESTREAM^X YOU CAN:

- Image cells directly in suspension with the resolution of a 60X microscope and the fluorescence sensitivity of the best flow cytometers
- Analyze highly heterogeneous samples and rare cell sub-populations at speeds exceeding 1,000 cells per second
- Perform phenotypic and functional studies at the same time using up to five lasers and 12 images per cell
- Quantitate virtually anything you can see using the IDEAS[®] software package's numerous pre-defined fluorescence and morphologic parameters

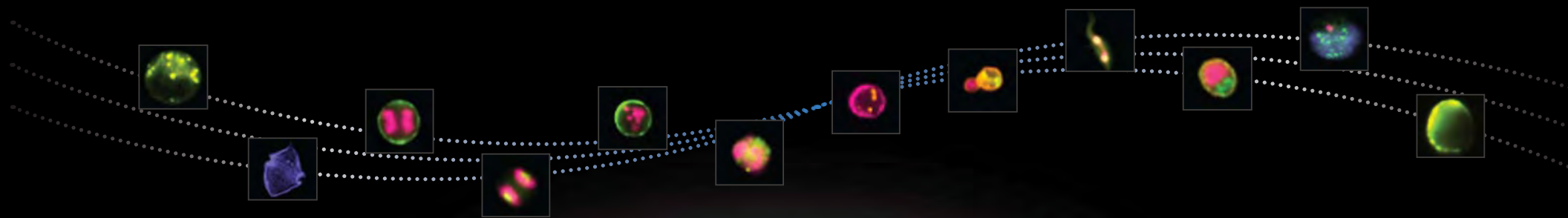

A Wealth of Applications

Cell Signaling, Co-localization, Shape Change, Internalization, and more

QUANTITATIVE IMAGING – NOT JUST OBSERVATIONS

Microscopy offers detailed cellular images and morphologic information, which are useful scientific tools for the study of cell function. However, the interpretation of microscopic imagery can be subjective, qualitative, and laborious.

Flow cytometry is excellent for quantitative phenotyping and yields statistically robust results by rapidly interrogating large numbers of cells. However, flow cytometry lacks any ability to image, so sub-cellular localization and cell function are measured indirectly.

By combining the speed, sensitivity, and phenotyping abilities of flow cytometry with the detailed imagery and functional insight of microscopy, the ImageStream^X overcomes the limitations of both techniques and opens the door to an extensive range of novel applications.

ANY APPLICATION YOU CAN IMAGINE

The ImageStream^X is designed to be a general-purpose platform for cellular studies and is not limited to the applications illustrated in this brochure. The ImageStream^X utilizes the same dyes and markers employed in microscopy and flow cytometry and can perform virtually any standard flow cytometry assay with the added value of visual confirmation.

FEATURED APPLICATIONS

The applications detailed on the following pages demonstrate the types of studies that can be performed using the ImageStream^X and its powerful companion IDEAS image analysis software.

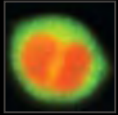

Cell Signaling

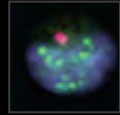

DNA Damage and Repair



Cell Death



Co-localization



Cell Cycle and Mitosis

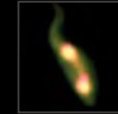

Parasitology

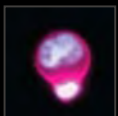

Cell-Cell Interactions



Autophagy



Microbiology

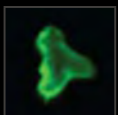

Morphology

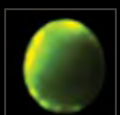

Targeted Immunotherapy

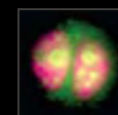

Oncology

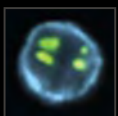

Internalization

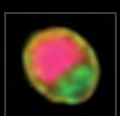

Stem Cell Differentiation

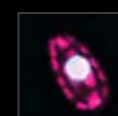

Oceanography

MORPHOLOGY

Change in cell shape is correlated with change in function, particularly in the case of macrophage activation, stem cell differentiation, and cellular response to drugs. The ImageStream^x measures cell shape using powerful, pre-defined features in the IDEAS image analysis software. One such feature is the Circularity score:

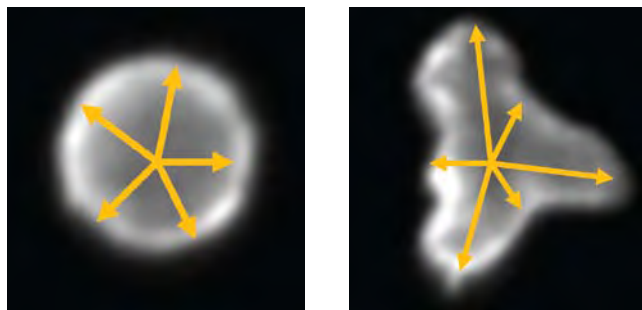

23.8

4.6

Circularity Scores

The Circularity score is a measure of how much the cell radius varies. Round cells (left) have high Circularity scores while irregularly shaped cells (right) have low Circularity scores.

Example: Shape Change in Primary Monocytes

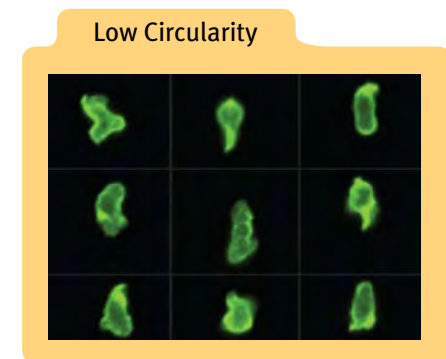
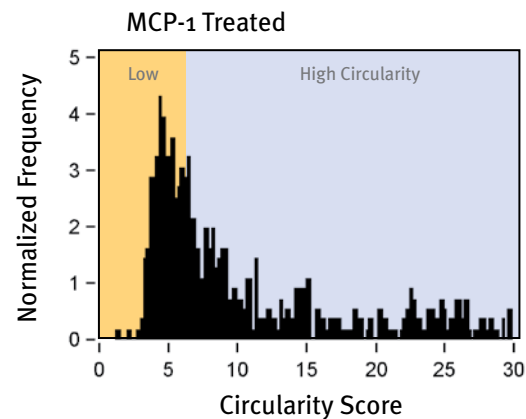
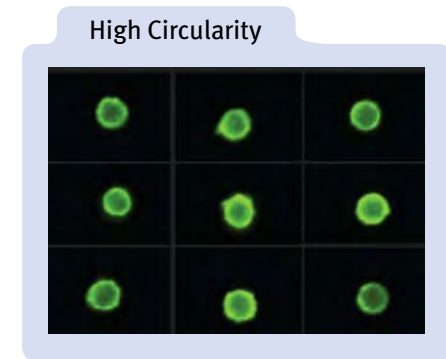
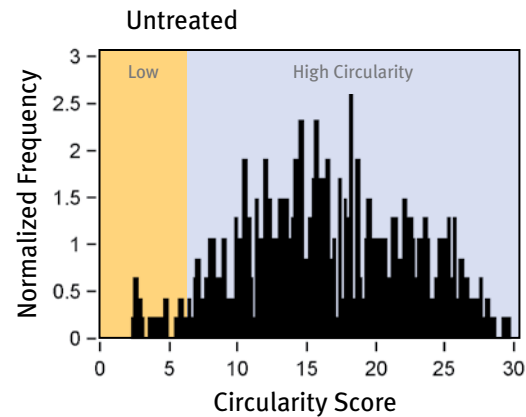

Chemoattractant MCP-1 induces monocyte shape change and migration to sites of inflammation, as evidenced by the significant decrease in the Circularity score of the MCP-1 treated sample relative to the untreated control. In contrast, treatments that reduce inflammatory response – such as drugs for autoimmune disorders – result in an increase in Circularity scores.

INTERNALIZATION

Measurement of the cellular uptake of specific ligands is important in the study of drug metabolism, host-pathogen interactions, and antigen processing and presentation. The IDEAS software objectively measures localization of internalized probes using a variety of parameters, including the Internalization score:

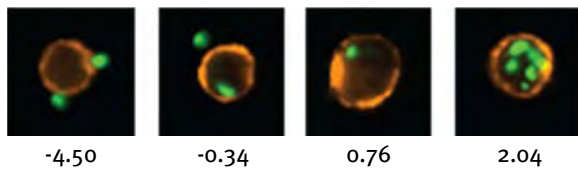

Internalization Scores

The Internalization score measures the relative amount of signal inside versus outside the cell. In this example, cells with Zymosan (green) bound to the membrane (orange) have negative Internalization scores, while cells that have internalized Zymosan have positive Internalization scores.

Example: Phagocytosis by Murine Macrophages

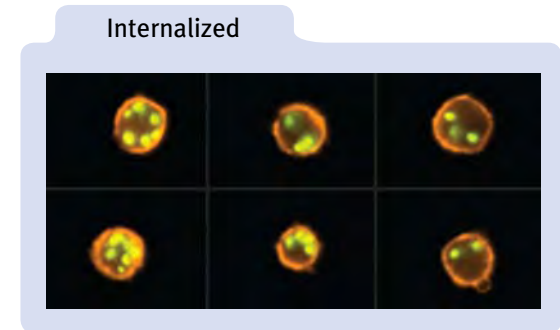
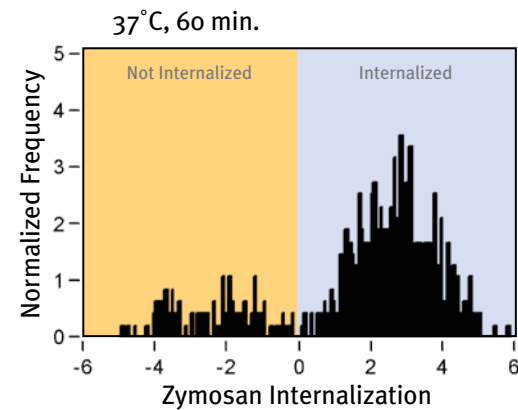
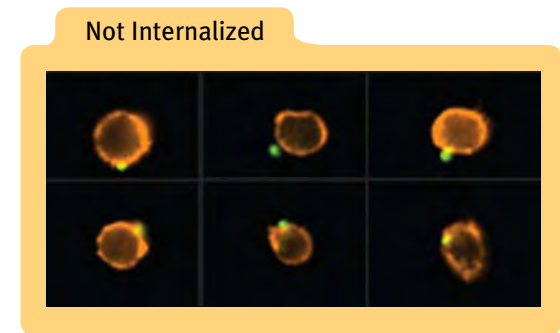
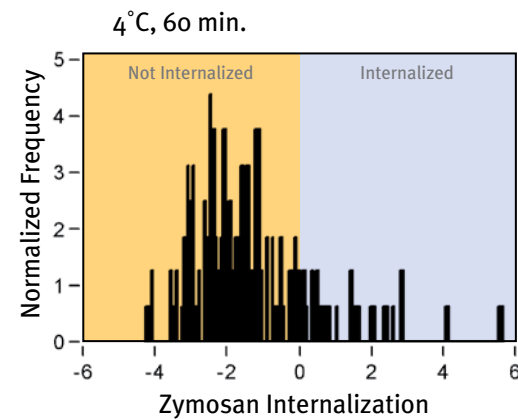

Phagocytosis of FITC-labeled Zymosan particles (green) by RAW cells (orange), a murine macrophage line, incubated at 4° C (top) and at 37° C (bottom). The Zymosan Internalization score is plotted for each sample at left and representative images of cells with surface-bound (top) or phagocytosed Zymosan (bottom) are shown at right.

CELL SIGNALING

Molecular translocation of transcription factors from the cytoplasm to the nucleus is a pivotal event in many processes critical to cellular activation, differentiation, and host defense. The IDEAS software package quantifies nuclear translocation events by automatically correlating the images of the transcription factor and the nucleus using the Similarity score.

Example: Translocation of NF- κ B in Whole Blood Leukocytes

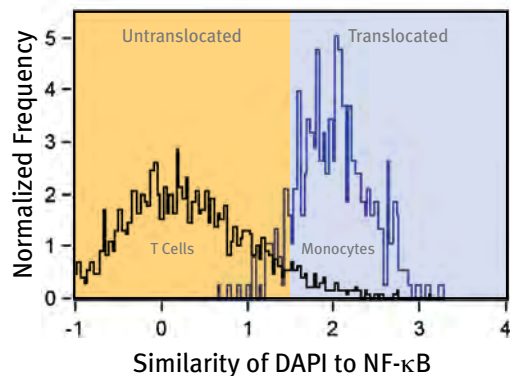

NF- κ B translocation is quantified in immunophenotypically-defined whole blood leukocytes imaged at 60X magnification. This example shows that lipopolysaccharide specifically induces NF- κ B nuclear translocation in monocytes (blue histogram, images at lower right) but not T cells (black histogram, images at upper right).

Untranslocated T Cells



Translocated Monocytes



CO-LOCALIZATION AND TRAFFICKING

The ImageStream^X greatly improves co-localization studies by combining the rapid collection of large numbers of cell images with objective measurement of the Similarity of bright image details.

Example: Internalization and Trafficking of CpGB in Primary Plasmacytoid Dendritic Cells (pDC)

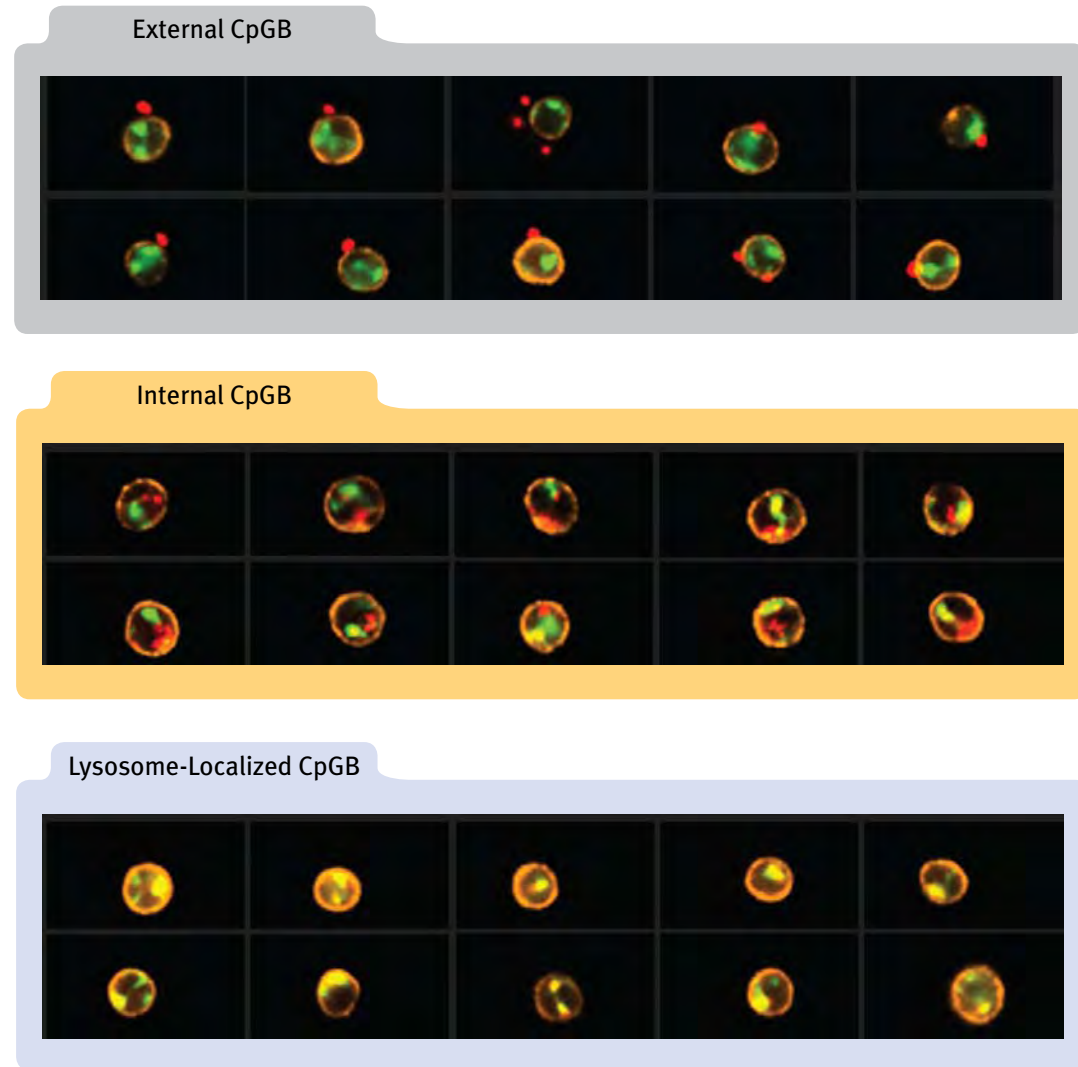
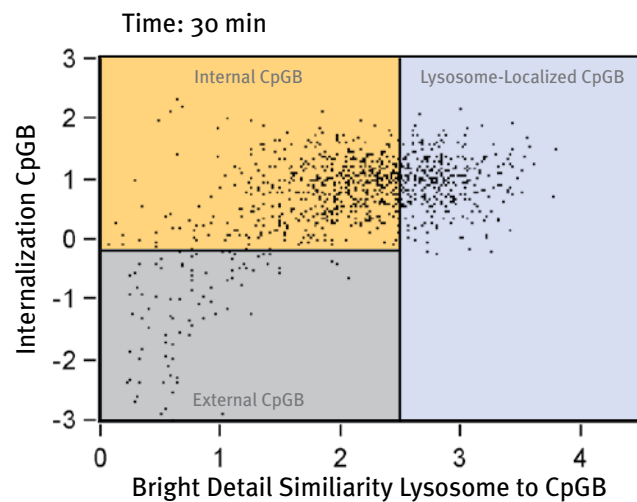

Lysosomal trafficking of CpGB within pDC is quantified using the Internalization (Y-axis) and the Bright Detail Similarity (X-axis) scores, and representative merged images of pDC (orange), CpGB (red), and lysosomes (green) are shown at right. Cells within the lower left region of the plot have surface-bound CpGB. As CpGB molecules enter the pDC, the Internalization score increases (upper left region). Once the CpGB traffics to the lysosomes, the similarity between the CpGB and lysosome image pair increases (upper right region).

Data courtesy of Dr. Patricia Fitzgerald-Bocarsly, University of Medicine and Dentistry, New Jersey.

The ImageStream^X Instrument

Think of the possibilities

The ImageStream^X is designed to gather more information from your cells than you ever thought possible. This breakthrough instrument is capable of imaging 1,000 cells per second with the fluorescence sensitivity of conventional flow cytometry, so you can perform image-based studies of dim markers on rare cells, even in heterogeneous samples. The ImageStream^X can accommodate up to five excitation lasers and simultaneously acquires up to 12 images per cell, so you can combine functional studies with detailed phenotypes.

If you think all of this power comes at the expense of image quality, think again. The ImageStream^X produces imagery comparable to the best fluorescence microscopes and operates at 60X, 40X, or 20X magnification, so you can study the fine details of objects as small as bacteria and as large as epithelial cells. Only the ImageStream^X combines the speed, sensitivity, and quantitation of flow cytometry with the visual detail of microscopy in a single platform.



Software that Turns Data into Understanding

IDEAS combines image analysis, statistical rigor, and visual confirmation in an easy to use package

Graphical Population Definitions

Define populations using familiar graphical tools and combine them with logical functions.

Comprehensive Population Statistics

Characterize your cell populations with a wide range of statistical metrics to reveal differences in cell morphology, phenotype, and function.

Inspect Your Populations

The Image Gallery allows you to see every image of every cell or perform a “virtual cell sort” to inspect and validate the cells within a specific population.

Wizards Simplify Analysis

Pre-configured and optimized analysis wizards are provided for many common applications.

Images for Every Dot

Every dot in every scatter plot is linked to the corresponding cell imagery. Simply click on a dot to see the associated cell images or vice-versa.

Flexible Image Display Tools

Create composite images, pseudo-color representations and a host of other image transformations for reporting and publication.

Graph What You See

Virtually anything you see in the imagery can be plotted as a histogram or dot plot. Hundreds of parameters are calculated for every cell, including fluorescence intensity, fluorescence location, cell shape, cell texture, and numerous other morphologic and photometric features.

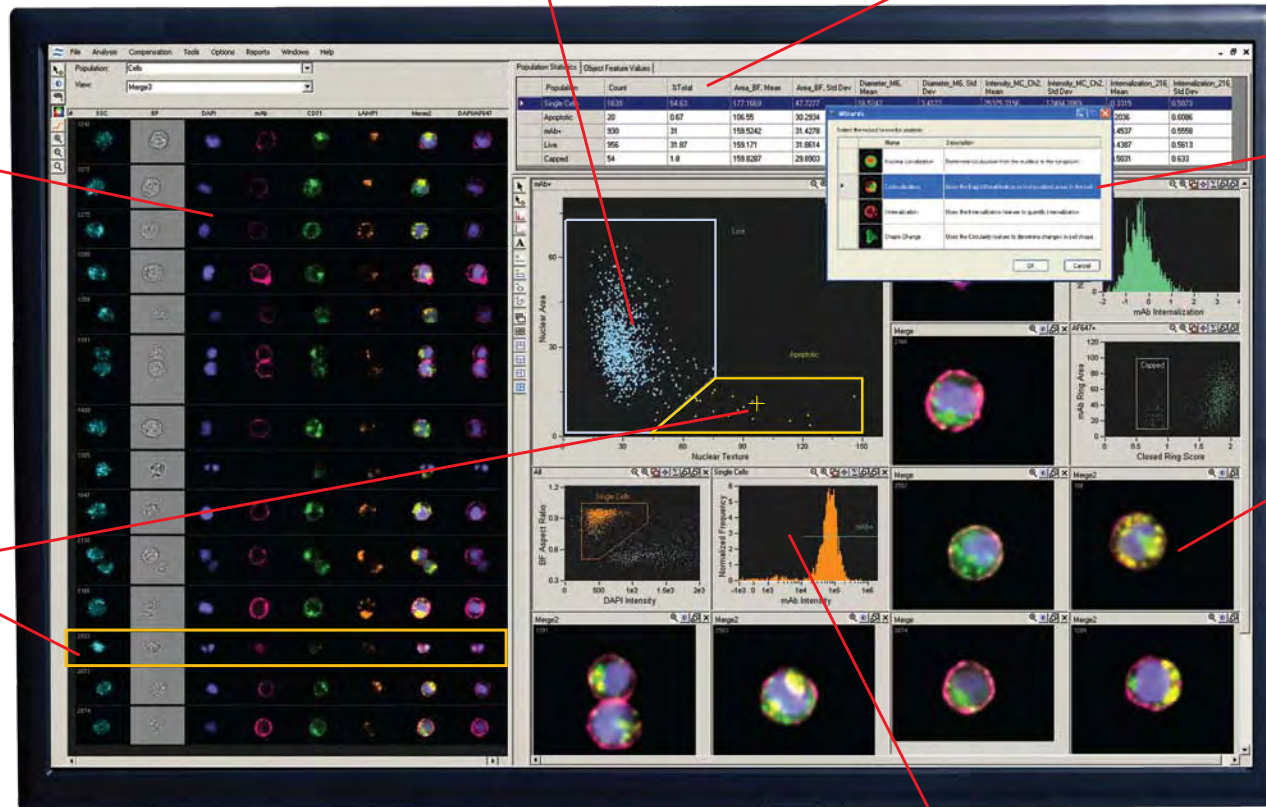

Modular Options

The ImageStream^X has numerous options to serve a wide range of needs and budgets



Five Lasers: The standard 488 nm laser of the ImageStream^X may be augmented with up to four additional lasers at 405, 560, 592, and 658 nm. A high power 488 nm laser upgrade is also available for even higher sensitivity.

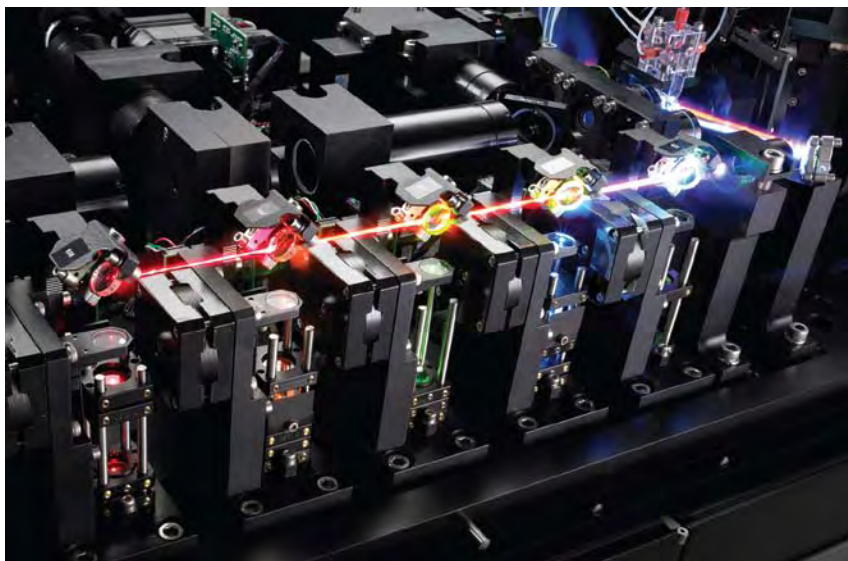

12 Image Channels: Up to 12 channels of detection are available with the addition of an optional second camera and associated optics.





MultiMag: The new MultiMag option provides 20X and 60X objectives lenses in addition to the standard 40X lens for greater flexibility and improved resolution. The 60X objective increases magnification for small objects such as yeast and bacteria and offers greater detail with mammalian and plant cells.

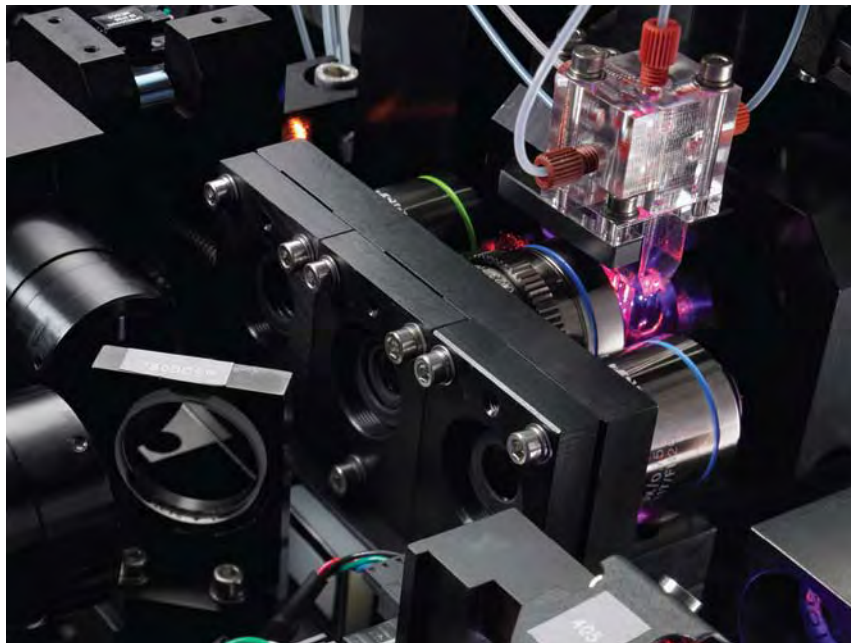

Full Color Brightfield: The Full Color Brightfield option provides a full spectrum brightfield light source that allows the ImageStream^x to replicate the RGB brightfield imagery of a microscope.

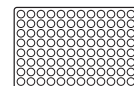

AutoSampler: The new AutoSampler option enhances productivity with unattended sample loading from multiwell plates.

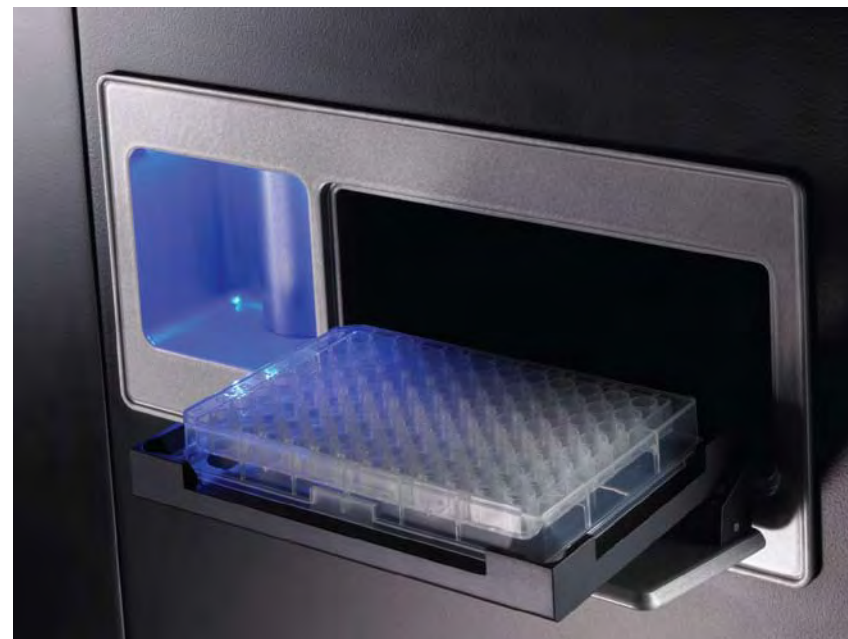

Extended Depth of Field: The EDFTM option incorporates Wavefront CodingTM technology from CDM Optics, which is a combination of specialized optics and unique image processing algorithms, to project all structures within the cell into one crisp plane of focus.

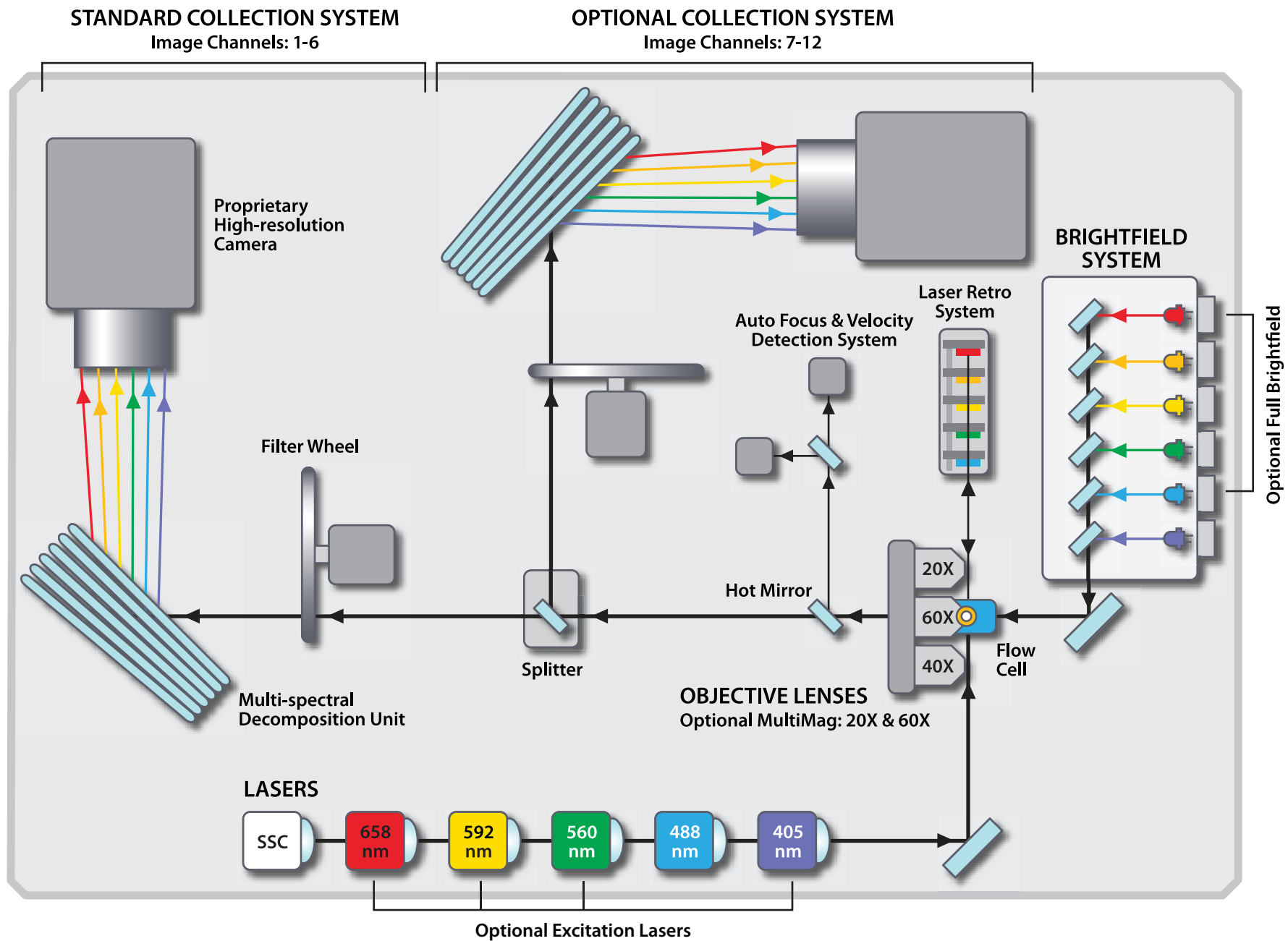

ImageStream^x Specifications

Advanced engineering creates exceptional performance

PERFORMANCE CHARACTERISTICS

	Magnification		
	40X	60X	20X
Numeric Aperture	0.75	0.9	0.5
Pixel Size	0.5 x 0.5 μm	0.3 x 0.3 μm	1.0 x 1.0 μm
Field of View	60 x 128 μm	40 x 76 μm	120 x 256 μm
Imaging Rate	1,000 cells/sec	600 cells/sec	2,000 cells/sec

SAMPLE CHARACTERISTICS

Volume: 50 μl

Utilization Efficiency: > 50% of sample

Throughput: 1 sample/min nominal

AUTOMATED INSTRUMENT OPERATIONS

Start up and shut down

Sample load and acquisition

Laser alignment, focus adjustment, calibration and self test

OPERATIONAL REQUIREMENTS

90-240 VAC, 50-60 Hz

100 Mbps ethernet, minimum

No external air or water necessary

PHYSICAL CHARACTERISTICS

36" W x 26" H x 24" D (91 cm x 66 cm x 61 cm)

350 lbs (159 Kg)

SPECTRAL IMAGING BANDS AND APPLICABLE DYES

CHANNEL 1 420-480 nm	CHANNEL 2 480-560 nm	CHANNEL 3 560-595 nm	CHANNEL 4 595-660 nm	CHANNEL 5 660-740 nm	CHANNEL 6 740-800 nm	CHANNEL 7 420-505 nm	CHANNEL 8 505-570 nm	CHANNEL 9 570-595 nm	CHANNEL 10 595-660 nm	CHANNEL 11 660-740 nm	CHANNEL 12 740-800 nm
Brightfield	FITC GFP YFP Acridine Orange Alexa Fluor 488 Alexa Fluor 500 Alexa Fluor 514 SYTO Spectrum Green LysoTracker Green DyeCycle Green Calcium Green-1 MitoTracker Green DyLight 488	DsRed Dil Cy3 R-phycoerythrin OPF Alexa Fluor 546 Alexa Fluor 555 DyLight 549 Calcium Orange	7-AAD PE-Texas Red (ECD) PE-Alexa Fluor 610 Propidium Iodide Spectrum Orange MitoTracker Red LysoTracker Red RFP mCherry Alexa Fluor 568 Alexa Fluor 594 Alex Fluor 610 DyLight 594 Texas Red	PerCP PerCP-Cy5.5 PE-Alexa Fluor 647 PE-Alexa Fluor 680 PE-Cy5 PE-Cy5.5 DRAQ5 Nile Blue	PE-Cy7 PE-Alexa Fluor 750 Darkfield (SSC)	DAPI Hoechst 33258 CFP Alexa Fluor 405 Marina Blue Pacific Blue Cascade Blue LIVE/DEAD Violet DyLight 405 eFluor 450 Spectrum Aqua	Alexa Fluor 430 Pacific Orange Cascade Yellow Lucifer Yellow Qdot 525 Qdot 545	Qdot 565 Qdot 585	Qdot 605 Qdot 625 eFluor 605 mCherry Alexa Fluor 568 Alexa Fluor 594 Alexa Fluor 610 DyLight 594 Texas Red Spectrum Red Calcium Crimson	Qdot 705 eFluor 650 Nile blue APC APC-Cy5.5 DyLight 649 MitoTracker Deep Red Alexa Fluor 647 Alexa Fluor 660 Alexa Fluor 680 DRAQ5 Cy5 Cy5.5	Qdot 800 APC-Cy7 APC-Alexa Fluor 750 APC-eFluor780 DyLight 750

Excitation Lasers:

405 nm diode laser

488 nm solid state laser

560 nm solid state laser

592 nm solid state laser

658 nm diode laser

Twelve image channel configuration shown.

Multiple lasers can be used in six image channel configuration.